

TECHNICAL INSTALLATION MANUAL

TONDO

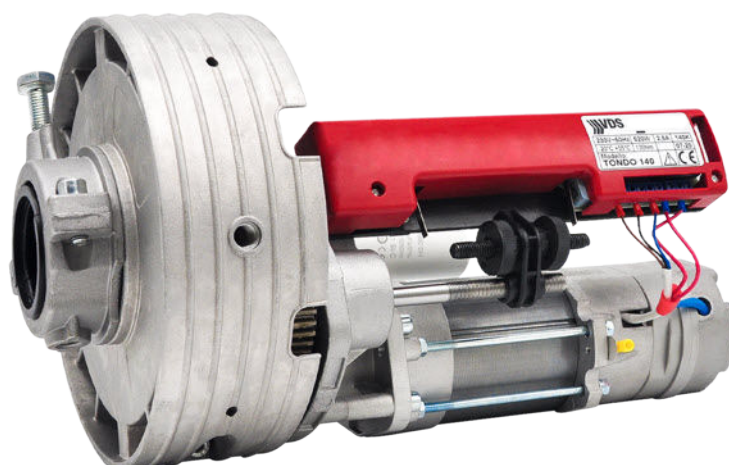

Rolling shutters



WARNING!! Before installing, thoroughly read this manual that is an integral part of the pack

Our products if installed by qualified personnel capable to evaluate risks, comply with norms UNI EN 12453, EN 12445



The CE mark conforms to European directive
EEC 89/336 + 92/31 + 93/68 D.L. 04/12/1992 N. 476.

CONTENTS

1	IMPORTANT SAFETY INSTRUCTIONS	3
2	TECHNICAL CHARACTERISTICS	3
3	TECHNICAL DATA.....	4
4	INSTALLATION INTRUCTIONS	4
5	ELECTRICAL WIRING SCHEME.....	5
6	FRONT SIGHT	6
7	ELECTROBRAKE APPLICATION DIAGRAM.....	6
8	BLOW UP VIEW OF THE ELECTROBRAKE	7
9	PERIMETRAL BAND.....	7

PURPOSE OF THE MANUAL

This manual was drawn up by the manufacturer and is an integral part of the product. It contains all the necessary information:

- to draw the attention of the installers to safety related problems;
- to install the device properly;
- to understand how it works and its limits;
- to use the device under safe conditions.

Strict observance of the instructions in this manual guarantees safe conditions as well as efficient operation and a long life for





the product. To prevent operations that may result in accidents, read this manual and strictly obey the instructions provided.

Instructions, drawings, photos and literature contained herein are the exclusive property of the manufacturer and may not be reproduced by any means.

1 IMPORTANT SAFETY INSTRUCTIONS

ATTENTION - FOR REASONS OF PERSONAL SAFETY IT IS IMPORTANT TO OBSERVE THESE INSTRUCTIONS.

RETAIN THESE INSTRUCTIONS

	<p>Do not let children play with fixed control devices. Keep the remote controls out of reach of children. Perform frequent checks on the system for any signs of unbalance and wear or damage to wires or springs. Do not use the equipment if it requires repair or regulation.</p>
	<p>These warning symbols serve to remind you to pay the maximum attention when the equipment is in use. They indicate the procedures to be followed to avoid risks to persons or things. This gearmotor is designed to function safely if installed and used in compliance with the following instructions. The equipment must be employed for residential uses and must be installed indoors.</p>
	<p>You are warned that incorrect installation can cause serious injuries. Follow all the installation instructions.</p>
	<p>Do not use command buttons that can simultaneously operate the equipment in both directions. Do not command more than one gearmotor with each button. Conduct frequent examinations on the installation to check for signs of unbalance and wear/damage to the wiring. Do not use the equipment if it requires repairs or adjustments. The product cannot be installed for heights of less than 2.5. m. The deployment of a device that guarantees omnipolar disconnection from the mains with an opening of at least 3 mm between the contacts is obligatory. Before installing the gearmotor for operating the rolling shutter remove all superfluous wires and disable any equipment not necessary for motorised movement. The control button must be placed in sight of the equipment, kept separate from the moving parts and at a height of at least 1.5 m. If the power cables are damaged they must be replaced by the constructor or his technical after-sales service or, in any case, by a similarly qualified person in order to avoid all risks. The gearmotor is designed for intermittent operation and is provided with an internal thermal protection that interrupts power supply in the event of overheating caused by continued use. The gearmotor automatically resets itself after a few minutes. However, regular operation will only be possible when the gearmotor cools down.</p>

2 TECHNICAL CHARACTERISTICS

Model	Torque Nm	R.P.M	Capacitor μ F	Voltage Volt	Current A	Power W	Termal min	Weight kg
TONDO 140	140	10	18	230	2.5	520	4	8
TONDO 140+EL	130	10	18	230	2.5	520	4	9
TONDO 180	180	10	22	230	3.1	650	4	10
TONDO 180+EL	170	10	22	230	3.1	650	4	11
TONDO 360+EL	360	10	40	230	5,21	1198	4	12,5

3 TECHNICAL DATA

- Die-cast aluminium body and rim
- Steel gears, roller bearings
- Rim mounted on bearing
- Drive shaft mounted on double ball bearings
- Asynchronous 4 pole motor 1.400 rpm
- Class B isolation
- Thermal protection on motor: 160°C.
- Easy limit-switch adjustment
- 6 mt. maximum shutter height
- Alimentation electric cable: 4x1 mm²
- Operating temperature: -20°C. ÷ 85°C.
- Fittings for electrobrake mounting.

4 INSTALLATION INTRUCTIONS



- 1) Drill a 10 mm diameter hole 5 cm from the centre of the shutter's shaft (see **FIG. 1**);
- 2) Remove the M10 screws from the gear of the gearmotor.
- 3) Remove the two semi-gears by unscrewing the two M8 screws (using a 6 mm hexagonal wrench);
- 4) Carefully remove, avoiding any folding, the black plastic roller carrier band;
- 5) Separate the two elements of the gearmotor (upper and lower body) acting on the four M8 screws (using a 6 mm hexagonal wrench);
- 6) Should the shutter shaft be less than 60 mm long, use the dedicated reducing sockets positioning them using the previously drilled 10 mm diameter hole as a reference (point 1);
- 7) Join the upper and lower bodies using the four M8 screws removed before;
- 8) Tighten the M10 screw without hexagon nut using a 17 mm wrench and ensure it enters the shutter shaft via the 10 mm hole (previously drilled);
- 9) Install the roller band in its appropriate housing;
- 10) Apply the semi-gears, holding them with the two M8 screws;
- 11) Tighten the M10 screw with nut so as to block the gearmotor on the shaft and tighten said nut;
- 12) Place the last canvas of the shutter on the shaft and drill a 12 mm diameter hole at the same location as the M10 threaded hole on the gear;
- 13) Tighten by hand the gear by 1-1½ turns by bringing the grip towards microswitch 1 (down) fig. 1 (it must turn easily);
- 14) Lock the shutter to the gearmotor using the M10 screw with washer (using a 17 mm wrench);
- 15) Make the electrical connections described in **FIG. 2** passing the 4x1 mm² cable inside the shutter shaft avoiding any contact with the rotating parts;
- 16) After having installed the mechanical parts and electrical contacts, proceed to regulate the end of travel;
- 17) Turn the end of travel grip by hand until you hear the click of the microswitch's trigger (down regulation completed);
- 18) Turn the other grip towards microswitch 2 (up). Switch on current to the gearmotor via the key selector or button to ensure that when rising the shutter stops at the correct point to regulate the position, adjust the grip, using solely and exclusively the electric commands taking all precautions to avoid manual lifting.
- 19) Should the shutter need to be installed contrary to the description in **FIG. 1**, the steps described above should be carried out to the contrary as microswitch 2 will stop the descent and microswitch 1 will stop the opening.

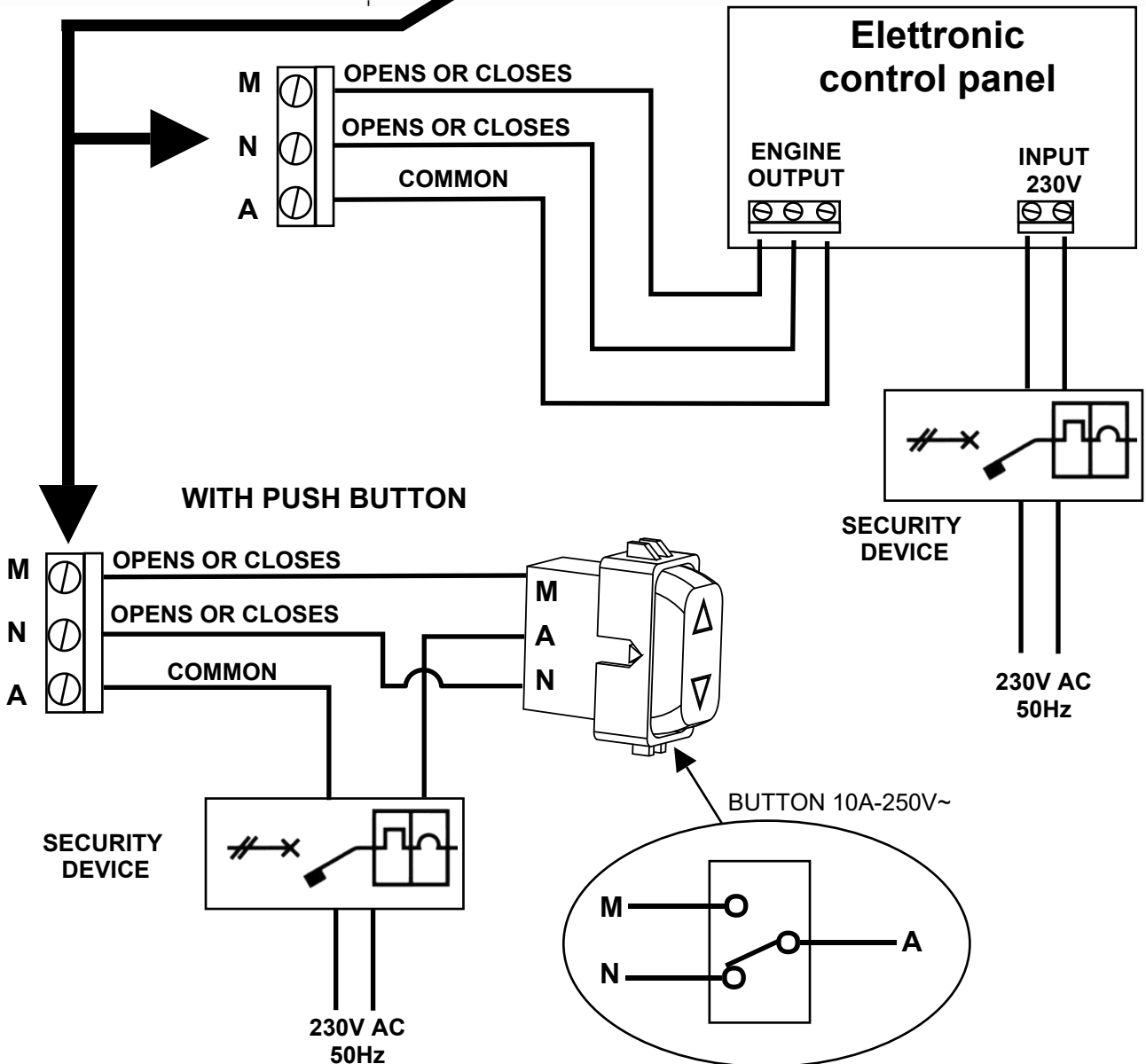
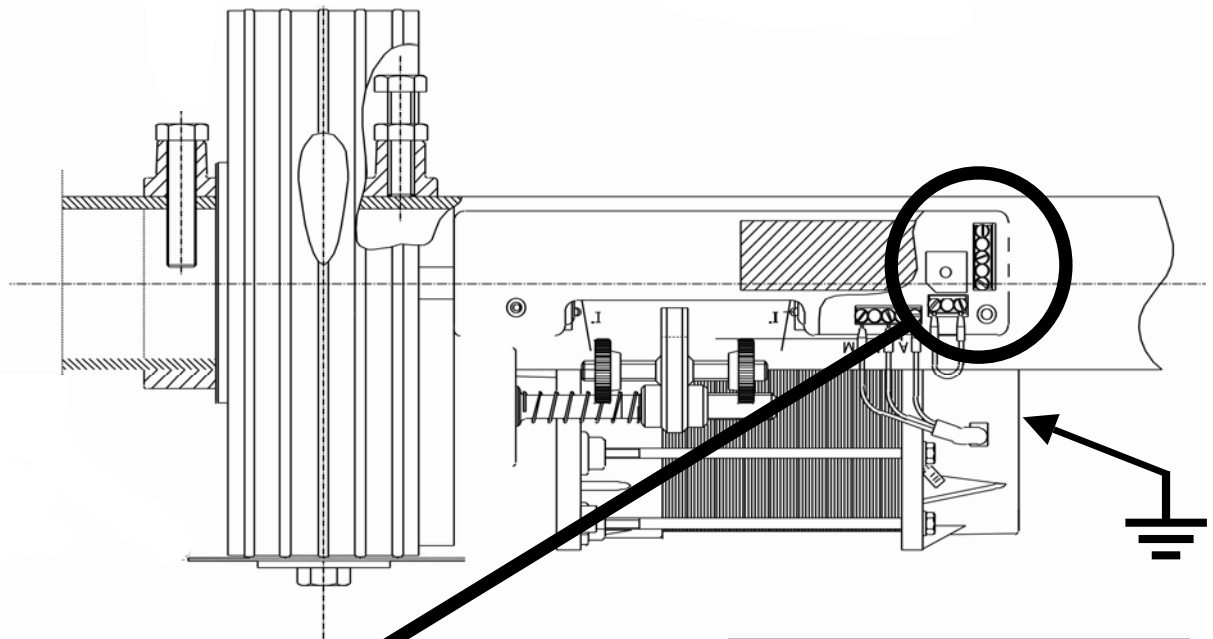

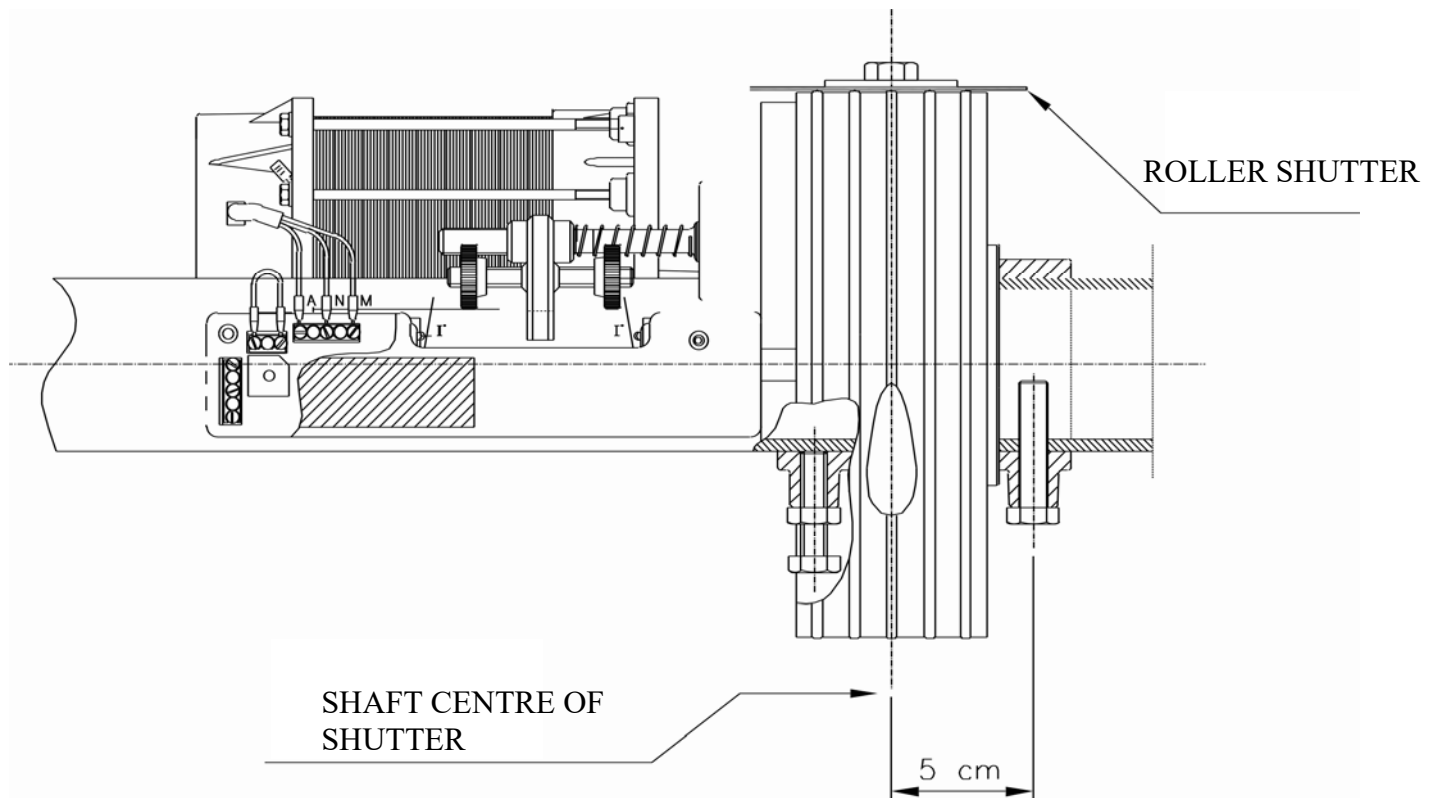

FIG. 1

7 ELECTROBRAKE APPLICATION DIAGRAM

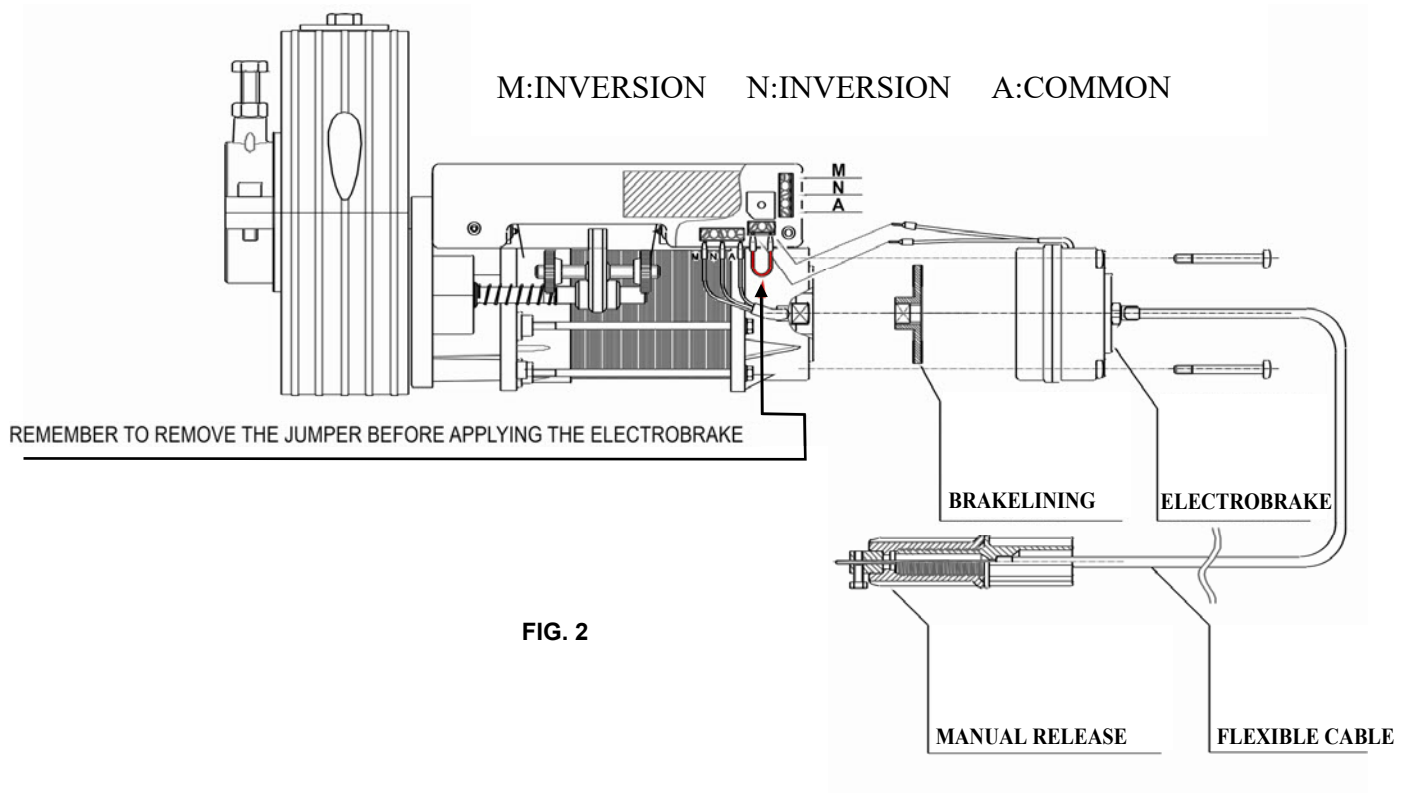
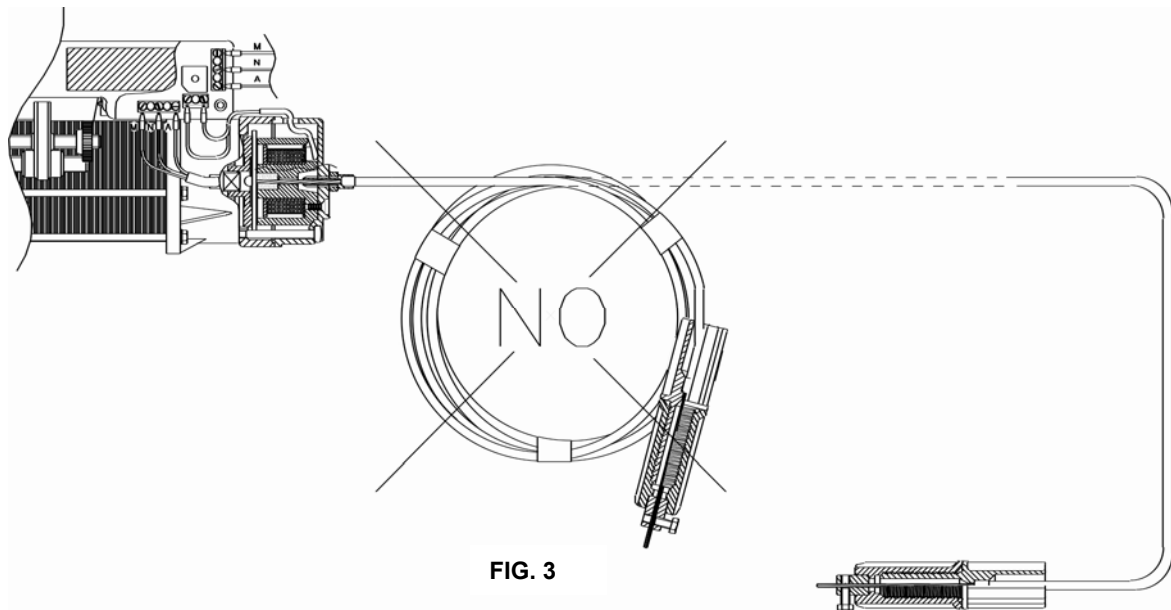

FIG. 2

8 BLOW UP VIEW OF THE ELECTROBRAKE



9 PERIMETRAL BAND

THE TONDO is built with a 200 mm crown wheel, which can be converted into a 220 mm crown wheel by the use of a perimetral band.

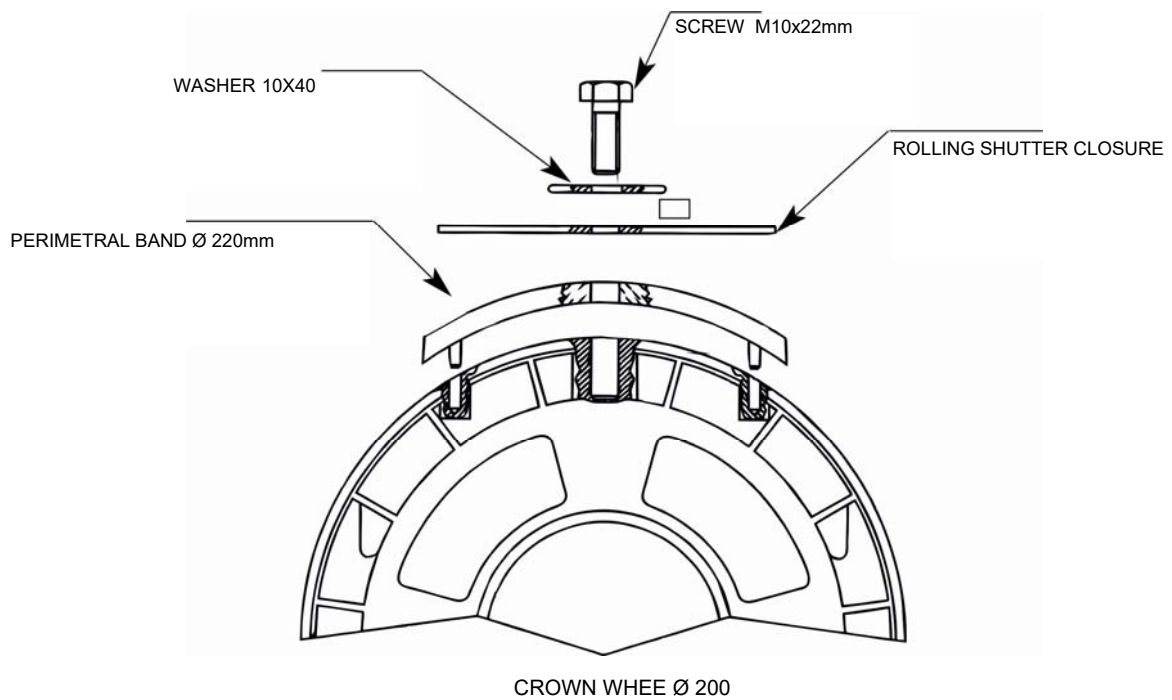

**The data and images are for guidance only
VDS reserves the right to change at any time characteristics of the products described in
its sole discretion, without notice.**



**Via Circolare p.i.p. N° 10
65010 Santa Teresa di Spoltore (PE) - ITALY
Tel. +39 085 4971946 - FAX +39 085 4973849
www.vdsautomation.com - info@vdsautomation.com**